

# FRENCH FITNESS

FF-DAP50

**FRENCH FITNESS DAP50 DUAL  
ADJUSTABLE PULLEY - 83" TALL (NEW)**

**ASSEMBLY MANUAL**



## FEATURES

- 12 gauge steel
- Heavy Duty Welded Construction
- Compact, space-efficient corner design
- Tube: 40\*80\*2.5mm rectangular steel tube
- 40\*40\*2.5mm rectangular steel tube
- 50\*50\*2.5mm stainless steel rectangular tube
- 2.5mm thick high-quality steel
- 16-position dual adjustable high/low pulley cable stations
- Adjustable cable ratio of 1:2 for extended cable travel
- Two (2) 200 lb steel weight stacks
- Integrated pull-up bars with multiple grip positions
- Full-length steel protective weight stack enclosures
- Easy-to-follow exercise illustrations
- Includes two nylon handles, accessories storage rack for squat bar, low row bar
- California Residents see Prop 65 WARNINGS

## TECH SPECS

- Dimensions: 40.9"L x 62.2"W x 82.6"H (L:1040mm, W:1580mm, H:2100mm)
- (2) 194lbs (90kg) Dual Weight Stacks
- Weight: 646lbs (283kg)
- Color: Black

## WARRANTY







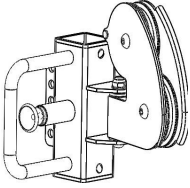
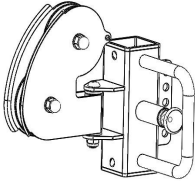
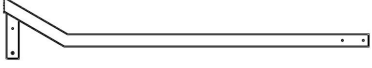
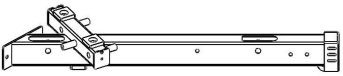

**10 Years Parts, 1 Year Labor (Light Commercial)**

# TABLE OF CONTENTS

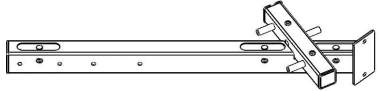
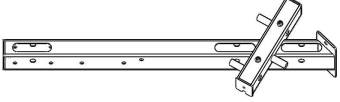
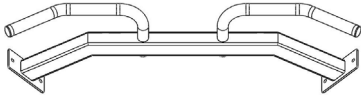
PARTS LIST .....	4
CLEAN GUIDE RODS .....	8
ASSEMBLY STEP 1 .....	9
ASSEMBLY STEP 2 .....	12
ASSEMBLY STEP 3 .....	14
ASSEMBLY STEP 4 .....	16
ASSEMBLY STEP 5 .....	18
ASSEMBLY STEP 6 .....	20
ASSEMBLY STEP 7 .....	21
ASSEMBLY STEP 8 .....	22
PACKING LIST .....	26
PACKING STEPS .....	29
CARTON PACKING STEPS .....	32

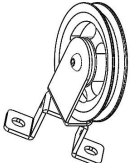

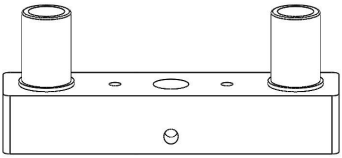

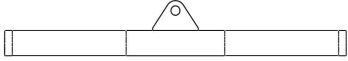
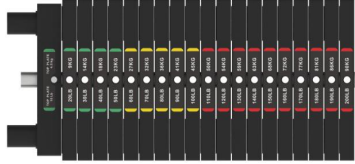

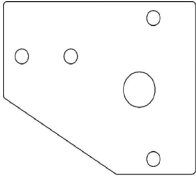
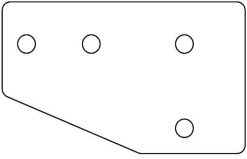

# PARTS LIST

## Parts list-1 (individual packaging)



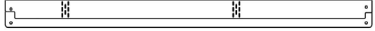
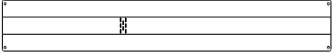

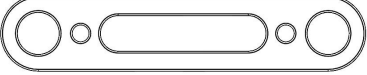
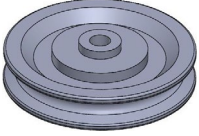
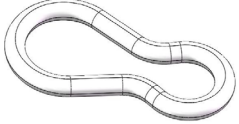
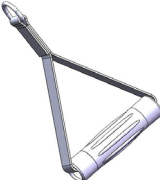
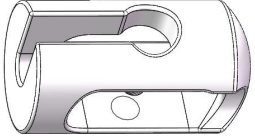

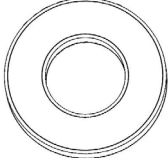

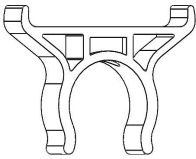

					
No 1	Functional trainer left pulley*1pc	No 2	Functional trainer right pulley*1pc	No 3	Rear column welding group*1pc
					
No 4	Left base welding group *1pc	No 5	Right base welding group *1pc	No 6	Right top welding group *1pc
					
No 7	Left top welding group *1pc	No 8	Upper beam assembly*1pc	No 9	Storage stand pipe welding group *1pc
					
No 10	Hanging pulley combination right*1pc	No 11	Hanging pulley combination left *1pc	No 12	Cast iron counterweight*2pcs
					
No 13	Push rod welding group *1pc	No 14	Low-stretch welding group *1pc	No 15	Counterweight label *1pc

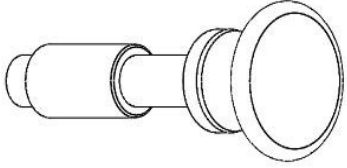
# PARTS LIST

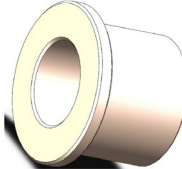
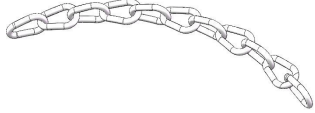
## Part list-2 (assembly parts)

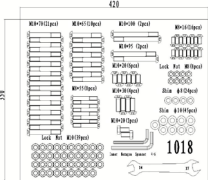
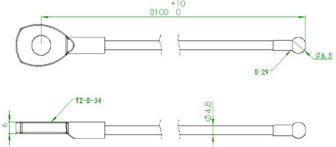
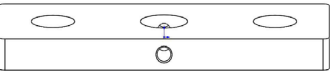
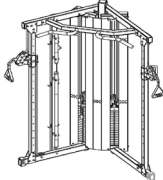

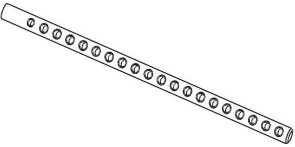
					
No 15	Upper assembly board * 4pcs	No 16	Lower assembly board * 4pcs	No 17	Small assembly board * 2pcs
					
No 18	Stainless steel lettering tube*2pcs	No 19	Side guard left *1pc	No 20	Side guard plate right*1pc
					
No 21	Front guard plate *1pc	No 22	Guide rod Ø25*2.0*1818*4pcs	No 23	Optical axis fixed block * 2pcs
					
No 24	Pulley*14pcs	No 25	Safety hook * 4pcs	No 26	Low pull handle*2pcs
					
No 27	Card slot set * 2pcs	No 28	Rubber cover * 2pcs	No 29	Round shock cushion * 4pcs

# PARTS LIST

					
No 30	Clip set * 4pcs	No 31	Plastic hook * 6pcs	No 32	aluminum alloy gold pins * 2pcs
					
No 33	Counterweight bolt * 2pcs	No 34	Pulley limit set * 20pcs	No 35	Chain 0.35m*2pcs
					
No 55	Biceps*1pc	No 56	Blister pack*1pc	No 57	Cable*2pcs
					
No 58	Weight Stack * 38pcs	No 59	Manual *1pc	No 60	Foot pocket *1pc
					
No 61	Center rod 20 holes	No 62	Black warning label*2pcs		

# PARTS LIST

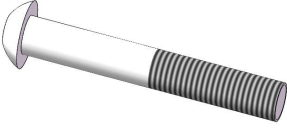
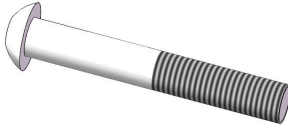
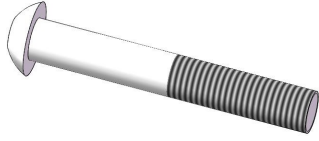
## Blister Pack Screw List-3

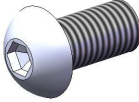
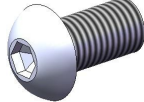
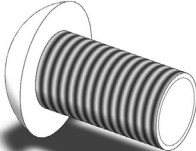
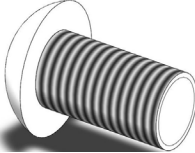
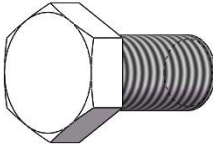
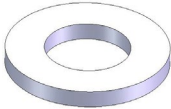
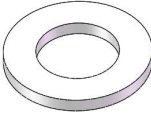
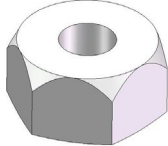
								
A	Hexagon socket flat head screw M10*100 *2pcs	B	Hexagon socket flat head screw M10*95* 2pcs	C	Hexagon socket flat head screw M10*70 *23pcs			
								
D	Hexagon socket flat head screw M10*65 *10 pcs	E	Hexagon socket flat head screw M10*30 * 4pcs	F	Hexagon socket flat head screw M10*20 *6pcs			
								
G	Hexagon socket flat head screw M8*20 *10pcs	H	Hexagon socket flat head screw M8*16 *12pcs	I	M10*20 external hexagon screw*2pcs			
								
J	Flat gasket Ø10 *45pcs	K	Flat gasket Ø8 *12pcs	M	M10 lock nut *39pcs			

# CLEAN GUIDE RODS

Step must be completed prior to installing. Failure to do so can leave residue from packaging and other sources stuck in the bushings. Guide rods need to make sure they are cleaned prior to installation otherwise this will cause the top plate to get stuck. It causes buildup in the bushings of the top plates. They just need to be cleaned out as well as the guide rods. Use Silicon Spray and fiber to remove any excess residue. These can be found around the house or at a nearby hardware store, pics below. Use silicon Spray and fiber.

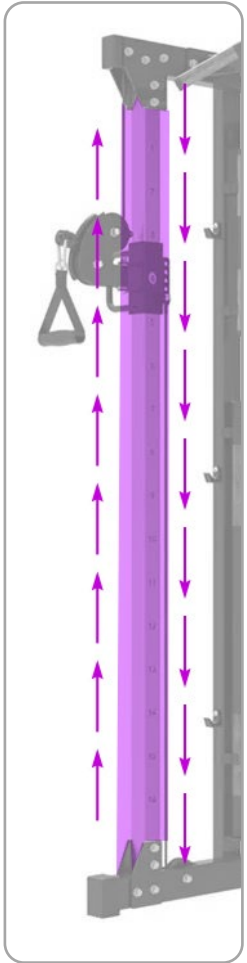
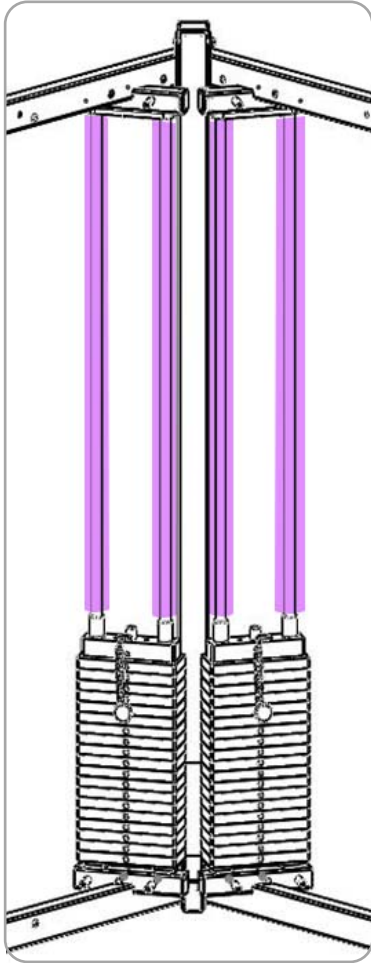
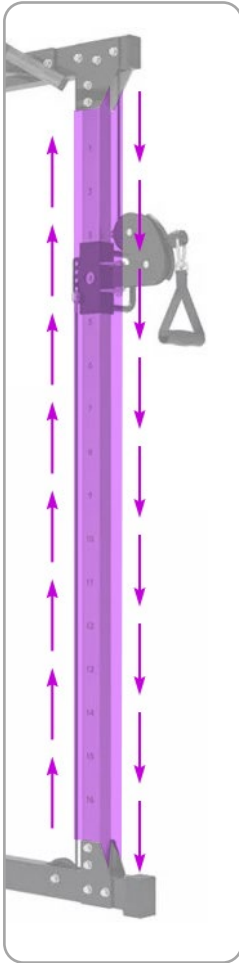
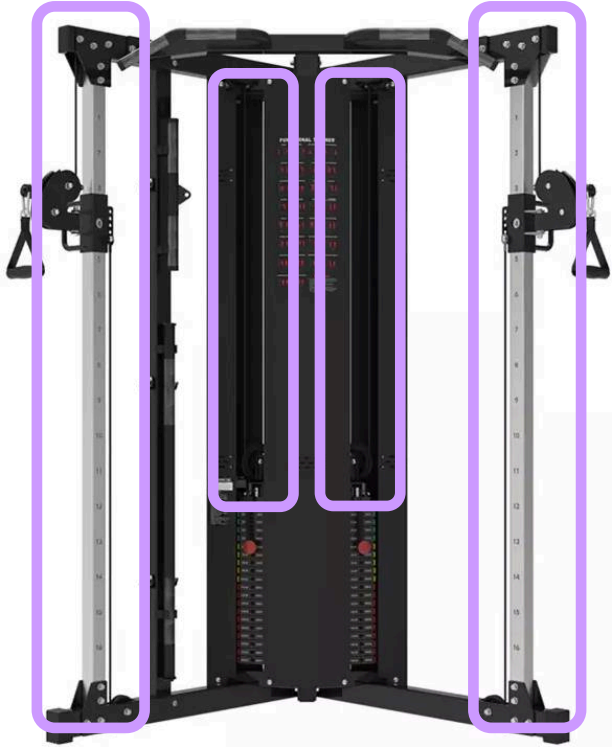



# ASSEMBLY STEP 1

## Assembly steps

Steps	No.	Name	QTY	project number	Name	QTY
<b>1</b>	4	Right base welding group	1	M	M10Locknut	1
	3	Rear column assembly	1	J	Ø10Gasket	3
	5	Left base welding group	1	I	M10*20Hexagon socket head screws	2
				A	M10*70Hexagon socket flat head screws	1

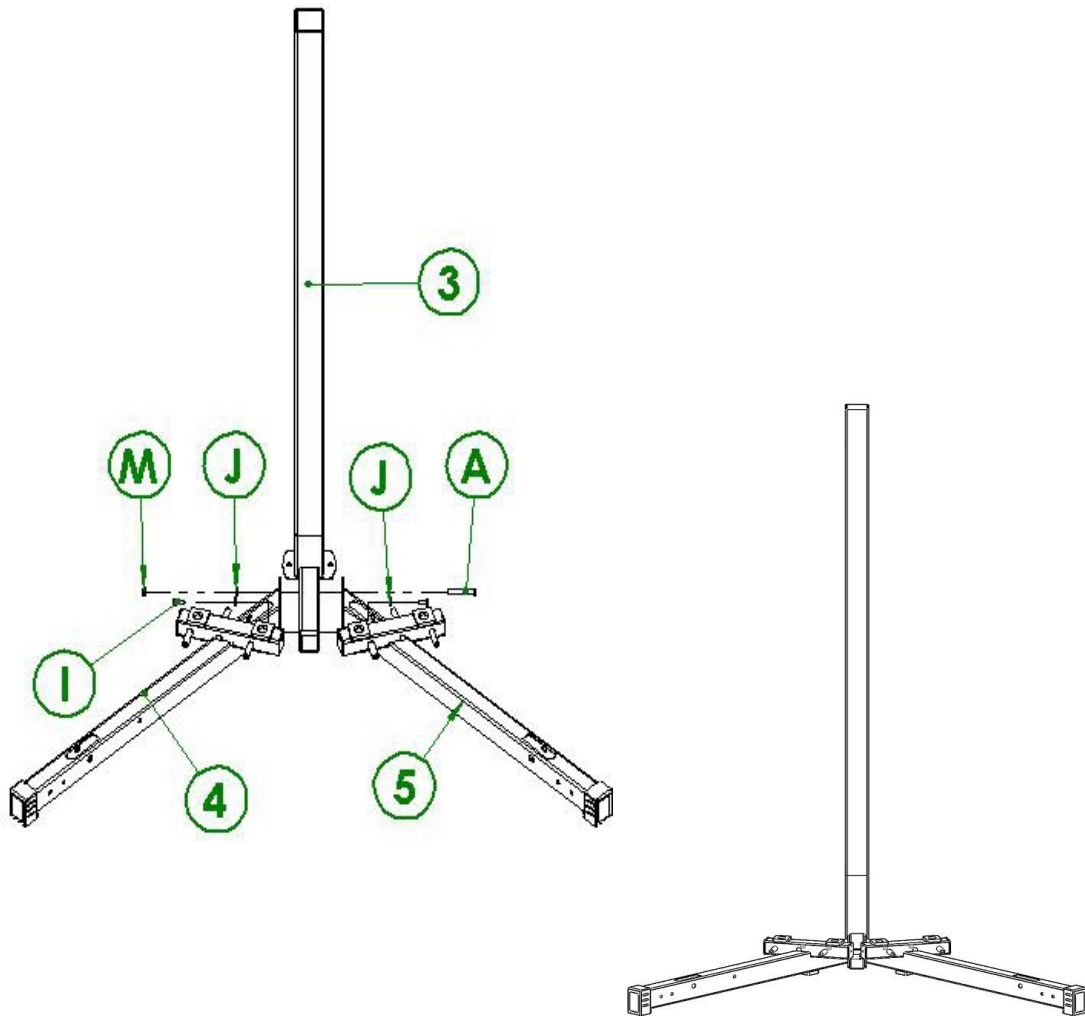

### No. 3 rear column welding group/1 pc

Steps	No.	Name	QTY	project number	Name	QTY
	70	50*75 pipe plug	1			
	71	75*75 pipe plug	1			

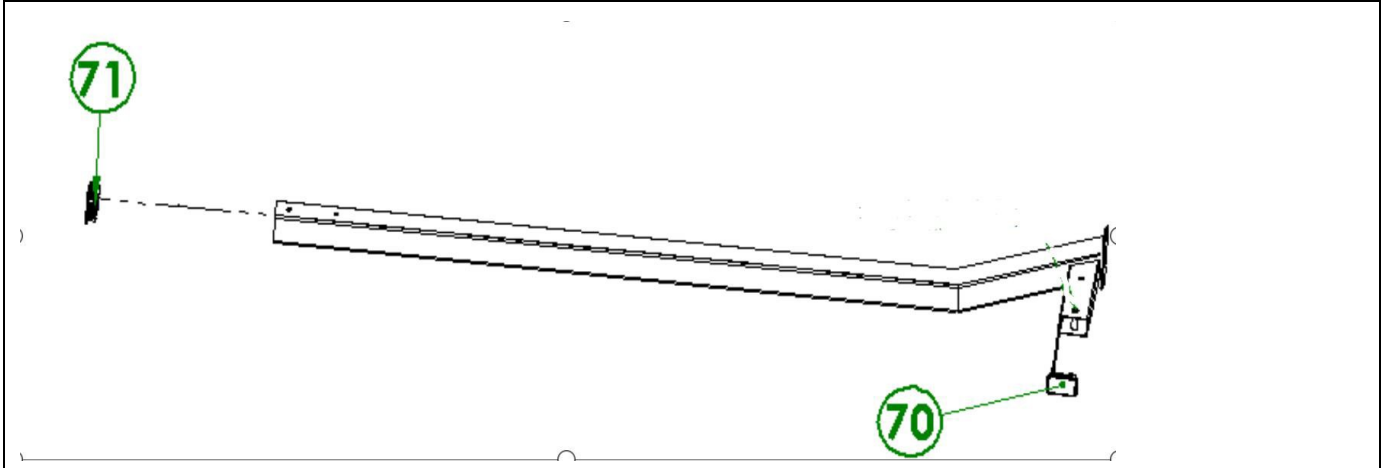

### No. 4 base welding group right/1 pc

Steps	No.	Name	QTY	project number	Name	QTY
	72	50*75Foot cover	1			

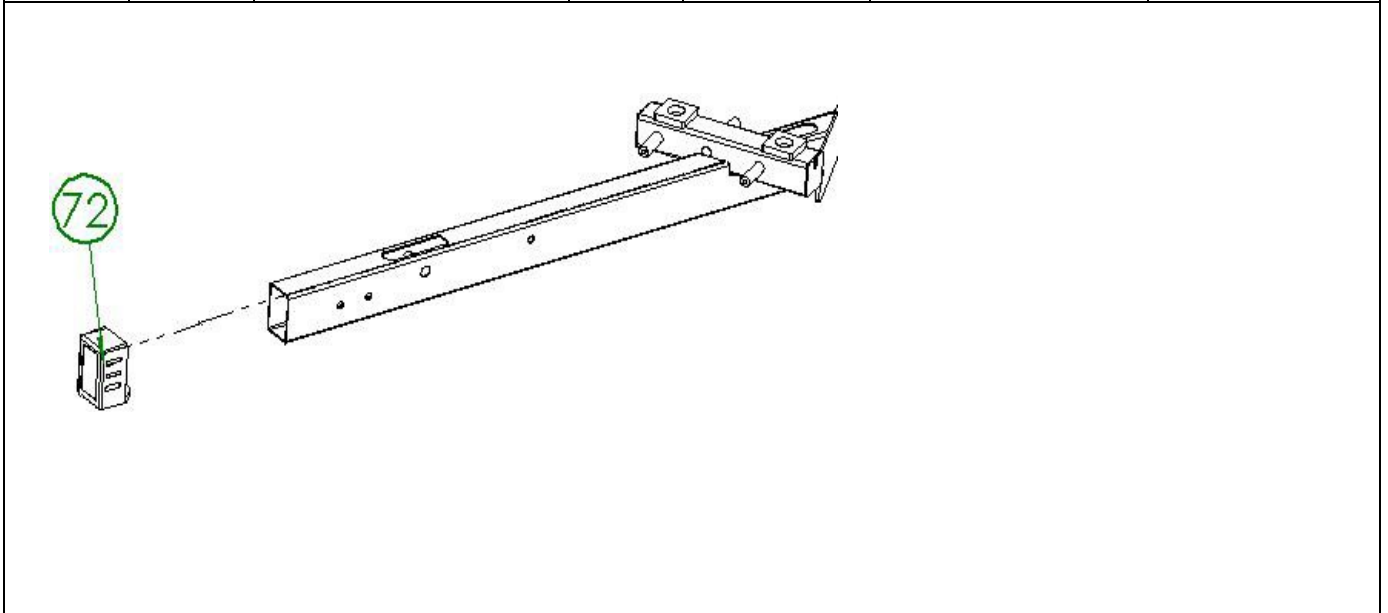

### No. 5 base welding group left/1 pc

Steps	No.	Name	QTY	project number	Name	QTY
	72	50*75Foot cover	1			

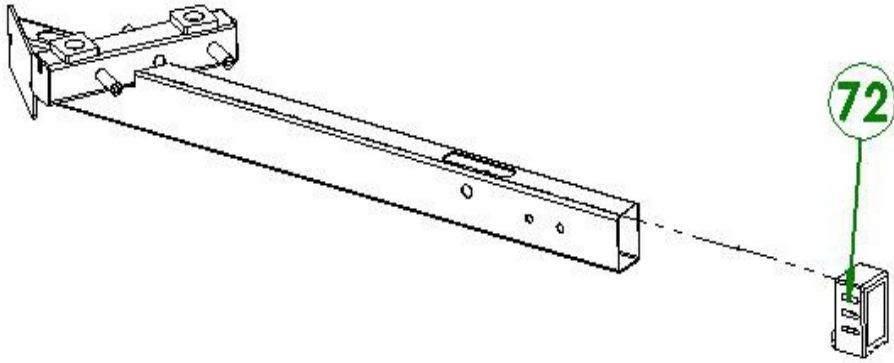

### No. 6 top welding group right/1 pc

Steps	No.	Name	QTY	project number	Name	QTY
	P	M10 Hexagon Blind Rivet Nuts	2			
	70	50*75 pipe plug	2			
	73	50*50 pipe plug	2			

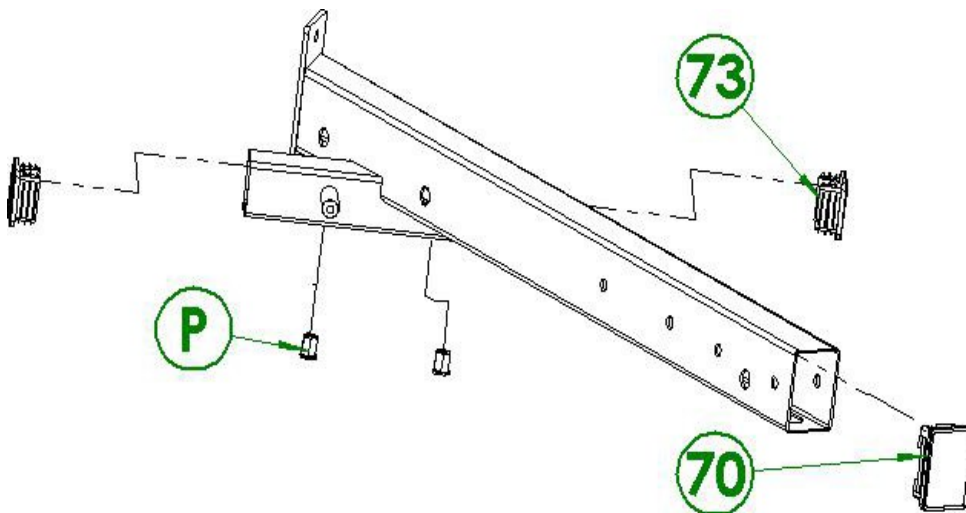

## ASSEMBLY STEP 2

### Assembly steps

Step NO	Item NO	Name	Qty	Item NO	Name	Qty
<b>2</b>	No.12	Cast iron counterweight	2	B	M10 * 95 hexagon socket flat round head screw	2
	No.23	Optical axis fixed block	2	J	Ø10shim	2
	No.22	Guide rodΦ25	4	E	M10 * 30 round head hexagon screw	4
	No.29	Circular damping pad	4	M	M10jam nut	2
	No.6	Top welding group right	1	No.7	Top weld group left	1

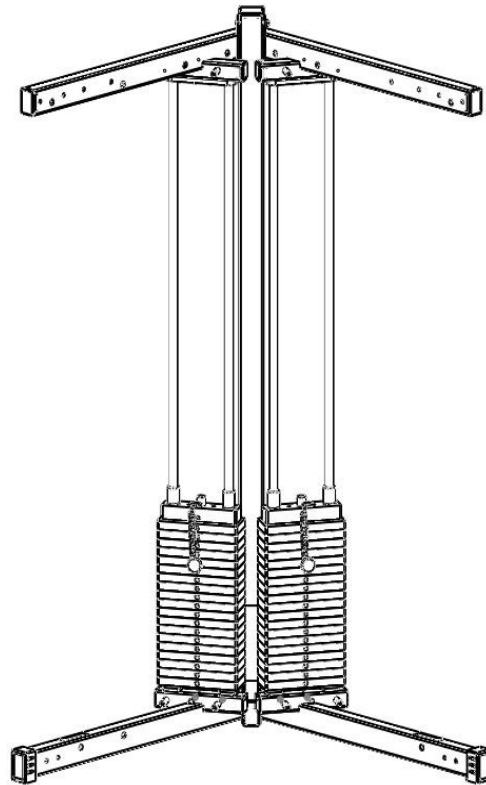
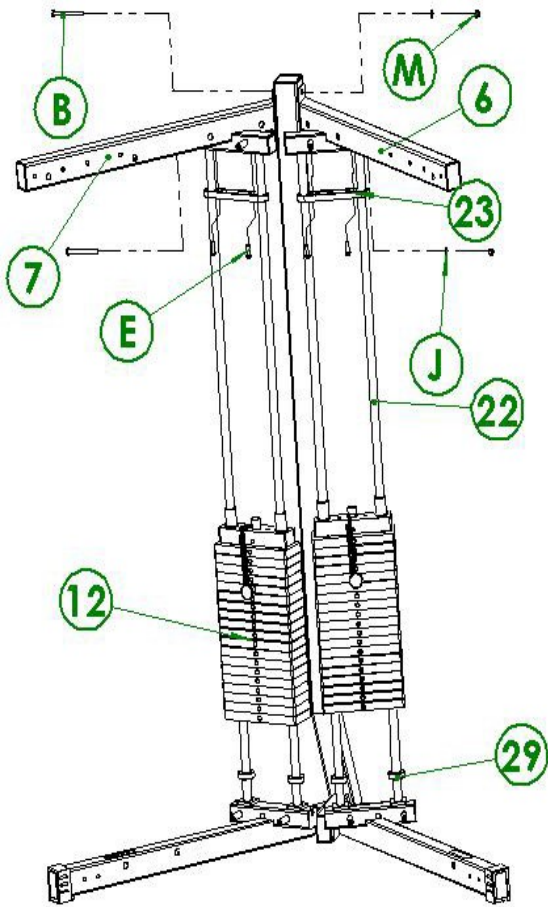

### 7 top welding group left / 1 pc

Step NO	Item NO	Name	Qty	Item NO	Name	Qty
	P	M10 hexagon riveting nut	2			
	No.70	50 * 75 pipe plug	2			
	No.73	50 * 50 pipe plug	2			

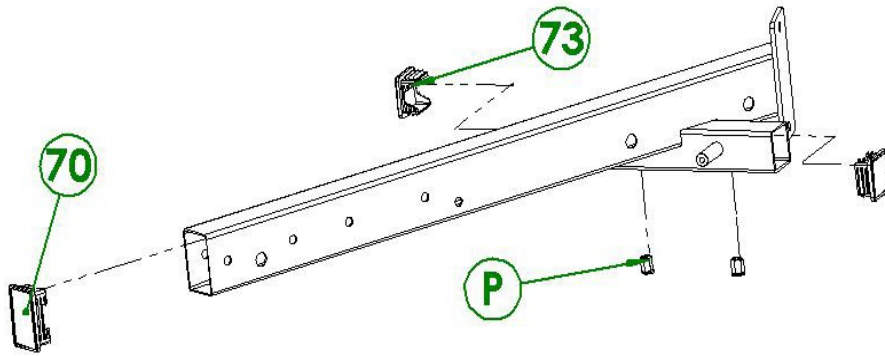

### 12 counterweight assembly / 2 pcs

Step NO	Item NO	Name	Qty	Item NO	Name	Qty
	No.76	Counterweight guide sleeve	2			
	No.78	Counterweight head	1			

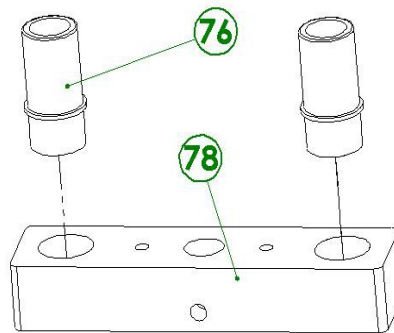
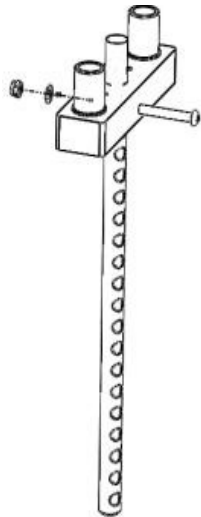

## ASSEMBLY STEP 3

### Assembly steps

Step NO	Item NO	Name	Qty	Item NO	Name	Qty
<b>3</b>	No.1	Crossfit pulley assembly left	1	C	M10 * 70 hexagon flat round head screw	8
	No.2	Crossfit pulley assembly right	1	J	Ø 10 gasket	8
	No.16	Lower assembly plate	4	M	M10jam nut	8
	No.18	Stainless steel lettering tube	2			

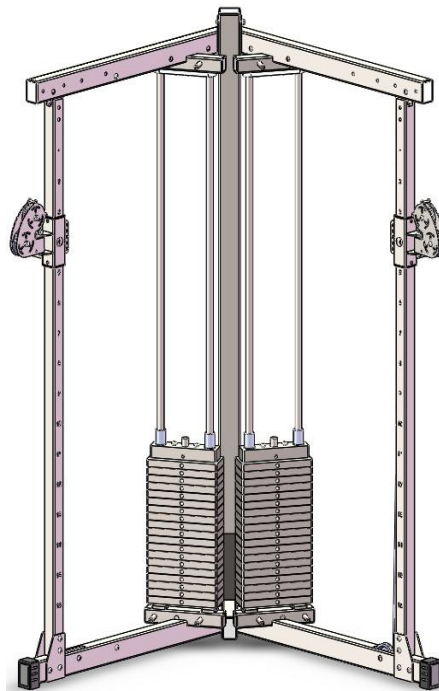
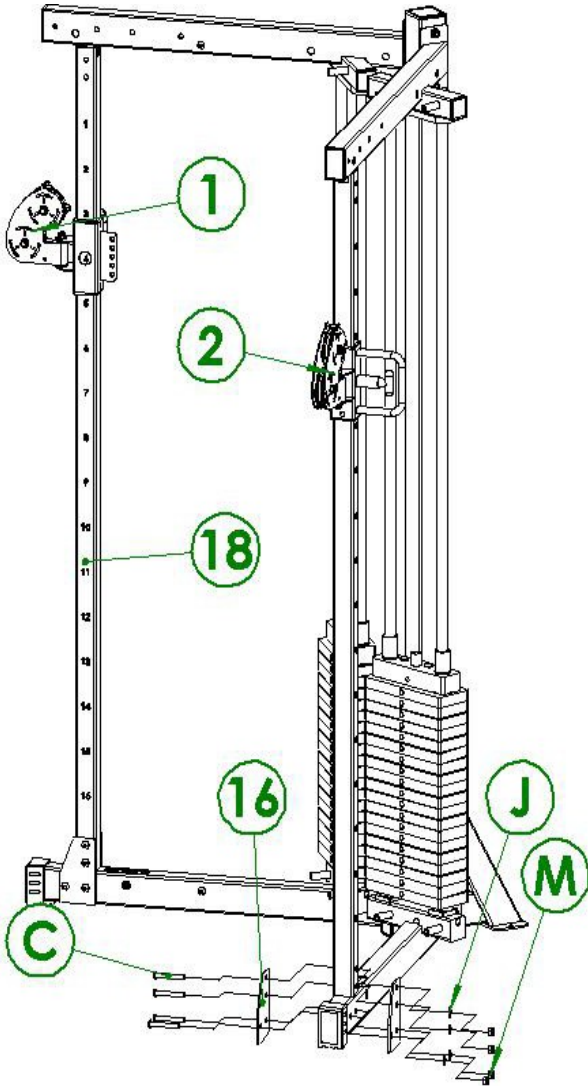

### No.1 crossfit pulley sleeve left \* 1 pc

Step NO	Item NO	Name	Qty	Item NO	Name	Qty
	No.24	Φ 90 pulley	2	J	Ø 10 gasket	3
	No.32	Aluminum alloy spring pin	1	W	M10 * 45 hexagon socket flat round head screw	2
	No.80	Reducing sleeve 60 to 50	2	S	M10 * 80 hexagon socket flat round head screw	1
	No.79	Crossfit group nylon cover	2	M	M10jam nut	1
	No.82	Snap cord pin	1	Y	M10nut	2

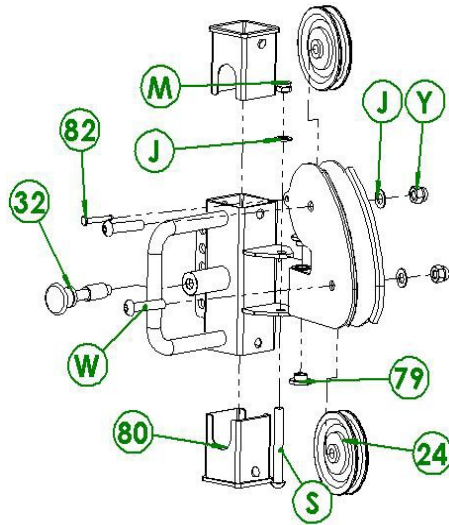

### No.2 crossfit pulley sleeve left \* 1 pc

Step NO	Item NO	Name	Qty	Item NO	Name	Qty
	No.24	Φ 90 pulley	2	J	Ø 10 gasket	3
	No.32	Aluminum alloy spring pin	1	W	M10 * 45 hexagon socket flat round head screw	2
	No.80	Reducing sleeve 60 to 50	2	S	M10 * 80 hexagon socket flat round head screw	1
	No.79	Crossfit group nylon cover	2	M	M10 jam nut	3
	No.82	Snap cord pin	1	Y	M10 nut	2

## ASSEMBLY STEP 4

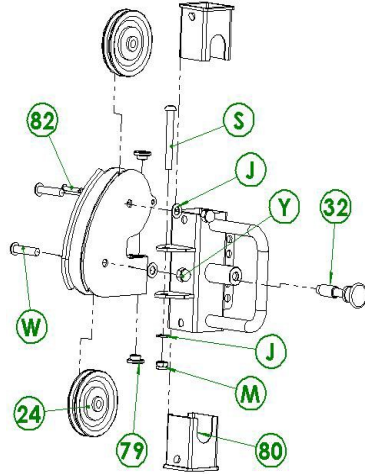

### Assembly steps

Step NO	Item NO	Name	Qty	Item NO	Name	Qty
<b>4</b>	No.28	Rubber cover	2	F	M10 * 20 hexagon socket flat round head screw	2
	No.24	Φ 90 pulley	10	M	M10 jam nut	2
	No.57	wire rope	2	J	Ø 10 gasket	2



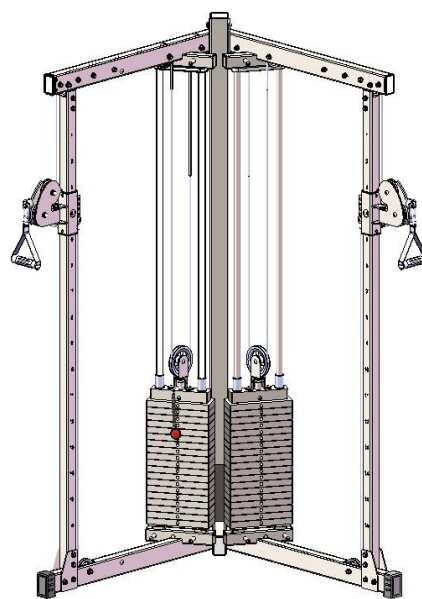
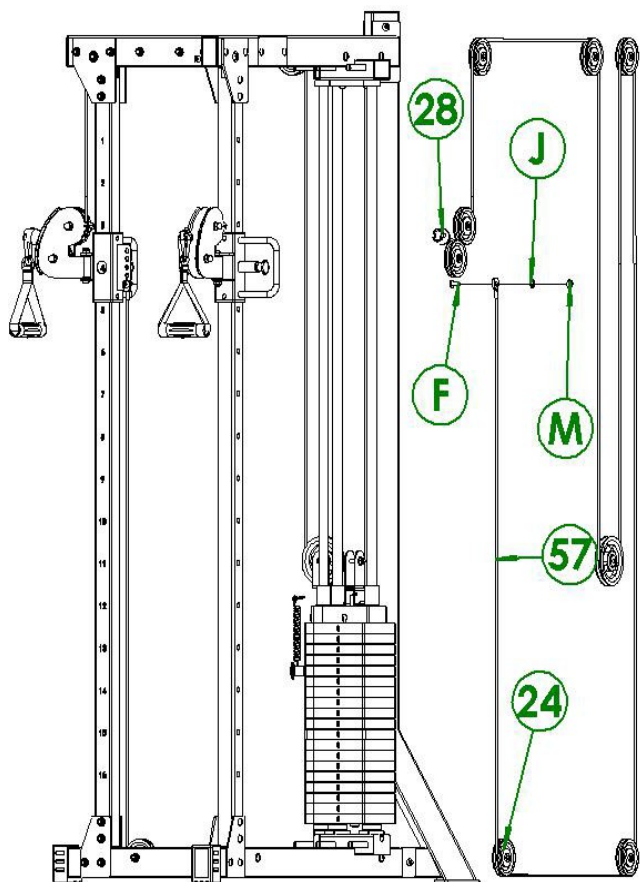

# ASSEMBLY STEP 5

## Assembly steps

Step NO	Item NO	Name	Qty	Item NO	Name	Qty
<b>5</b>	No.34	Pulley limit sleeve	20	J	Ø 10 gasket	14
	D	M10 * 65 hexagon socket flat round head screw	10	No.10	Lifting pulley assembly right	1
	F	M10 * 20 hexagon socket flat round head screw	4	No.11	Lifting pulley assembly left	1
	M	M10jam nut	10			

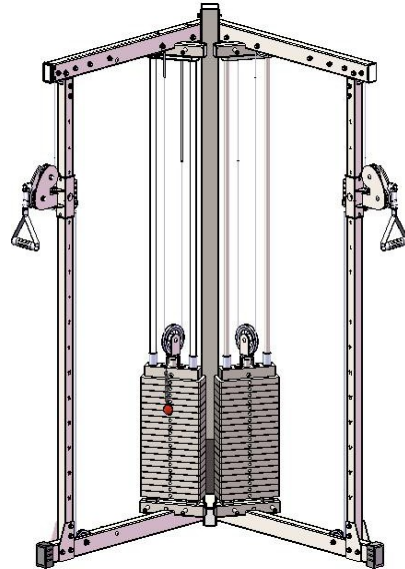
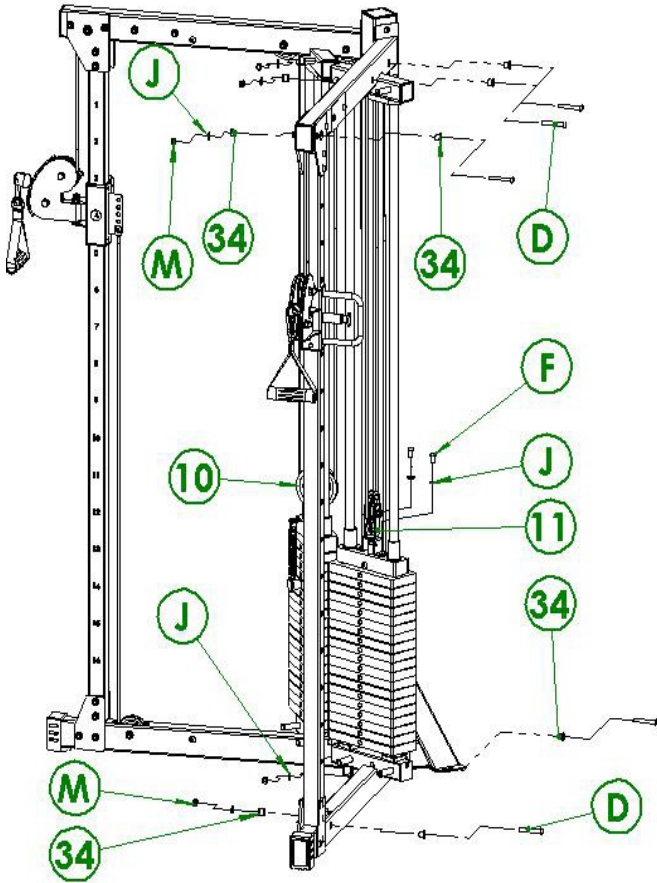

### 11 pulley assembly left

Step NO	Item NO	Name	Qty	Item NO	Name	Qty
	No.75	Φ 120 pulley	1	J	Ø 10 gasket	1
	M	M10jam nut	1			
	W	M10 * 45 hexagon socket flat round head screw	1			

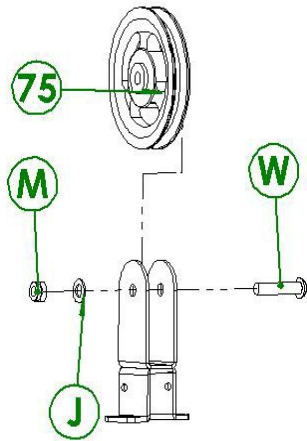

### 10 pulley assembly Right

Step NO	Item NO	Name	Qty	Item NO	Name	Qty
	No.75	Φ 120 pulley	1	J	Ø 10 gasket	1
	M	M10jam nut	1			
	W	M10 * 45 hexagon socket flat round head screw	1			

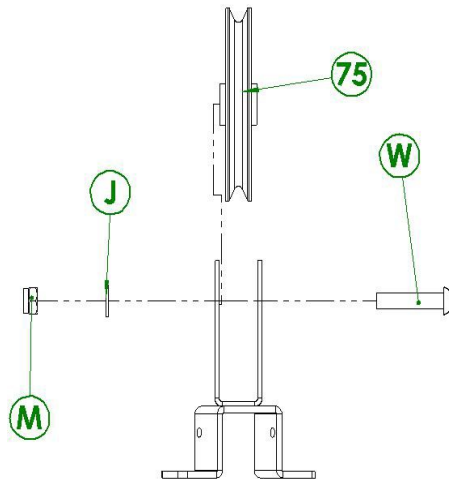

# ASSEMBLY STEP 6

## Assembly steps

Step NO	ITEM NO	Name	Quantity	ITEM NO	Name	Quantity
<b>6</b>	NO.8	Beam as-upper	1	J	Ø10shim	12
	NO.17	Small assembly plate	2			
	NO.15	Upper assembly plate	4			
	C	M10*70Hexagon socket flat round head screw	12			
	M	M10Lock nut	12			

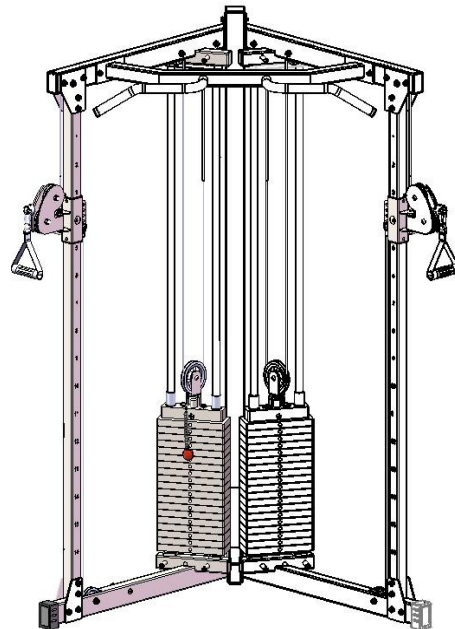
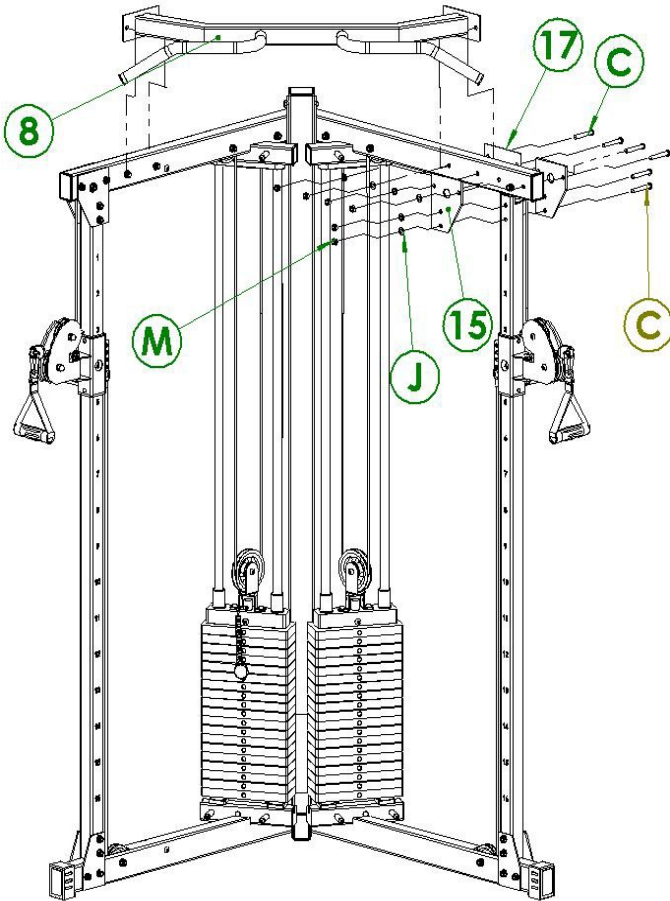

# ASSEMBLY STEP 7

## Assembly steps

Step NO	ITEM NO	Name	Quantity	ITEM NO	Name	Quantity
<b>7</b>	NO.30	Clip sleeve	4	A	M10*100Hexagon socket flat round head screw	2
	NO.9	Storage pipe welding group	1	G	M8*20Hexagon socket flat round head screw	10
	NO.31	Plastic hook	6	J	Ø10shim	2
				M	M10Lock nut	2

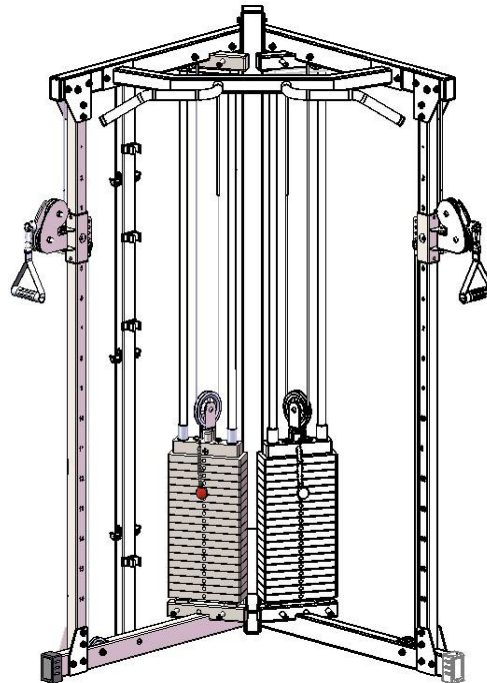
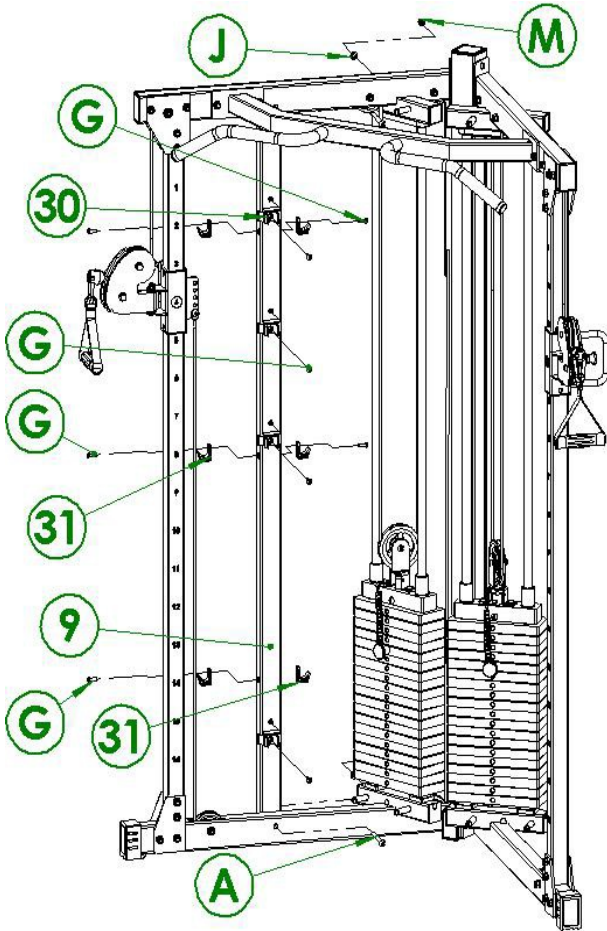

# ASSEMBLY STEP 8

## Assembly steps

Step NO	ITEM NO	Name	Quantity	ITEM NO	Name	Quantity
<b>8</b>	NO.14	Low tension welding group	1	NO.21	Front guard	1
	NO.13	Push rod welding group	1	K	Ø8shim	12
	NO.19	Side guard left	1	H	M8*16Hexagon socket flat round head screw	12
	NO.20	Side guard right	1			

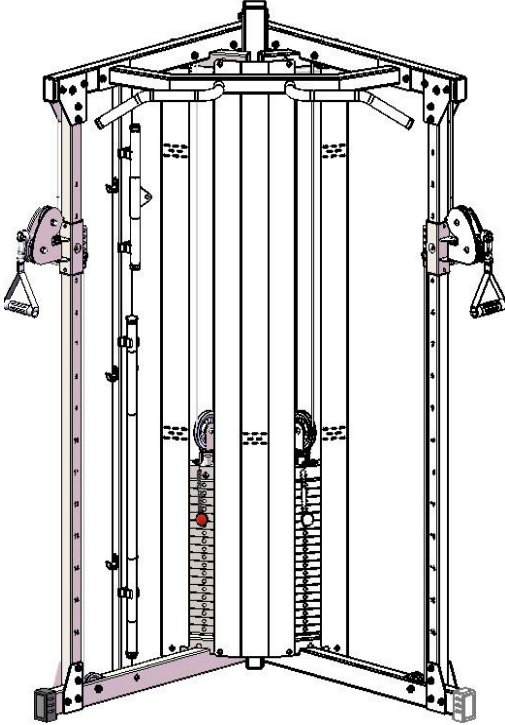
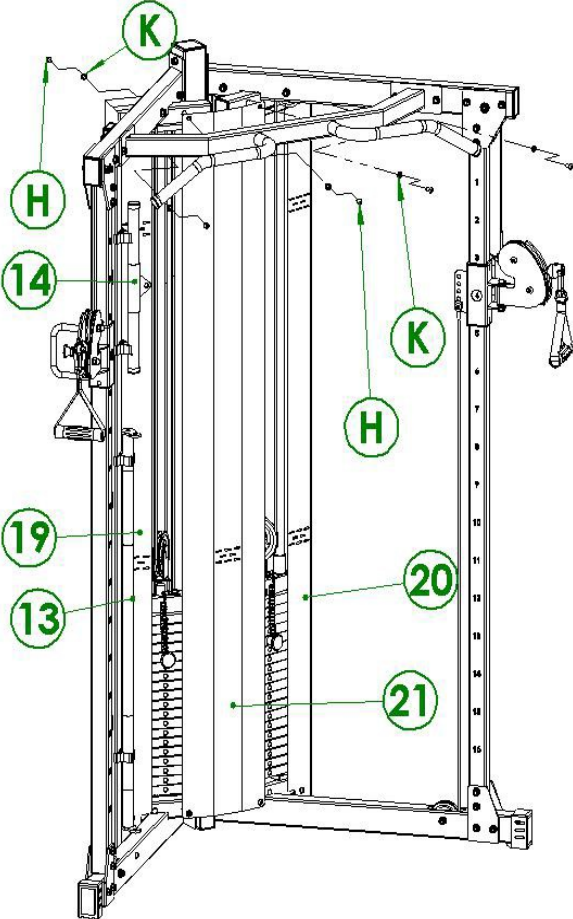

### NO.8 Beam as-upper\*1pc

Step NO	ITEM NO	Name	Quantity	ITEM NO	Name	Quantity
	NO.74	Φ32 Round pipe plug	4			

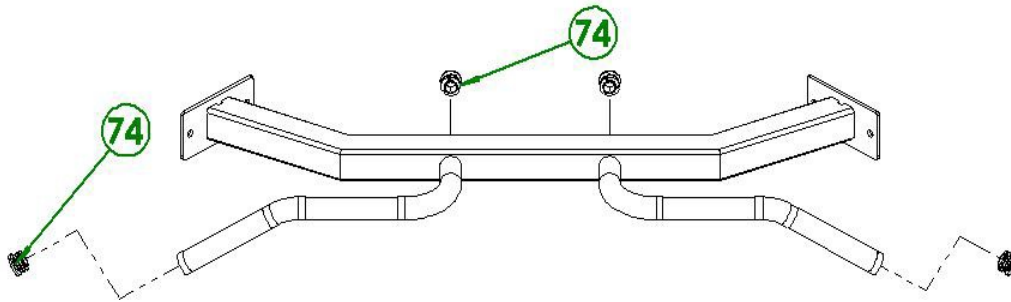

### NO.14 Low tension welding group\*1pc

Step NO	ITEM NO	Name	Quantity	ITEM NO	Name	Quantity
	NO.74	Φ32 Round pipe plug	2			

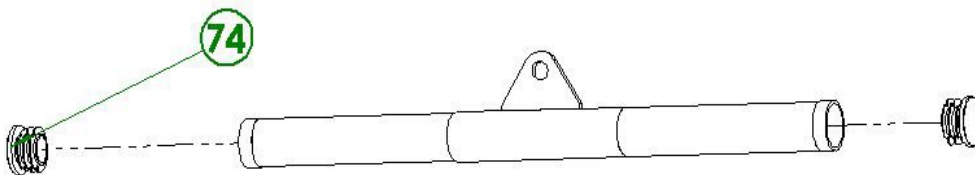

## NO.9 Storage pipe welding group\*1pc

Step NO	ITEM NO	Name	Quantity	ITEM NO	Name	Quantity
	NO.81	40*60Square pipe plug	2			
	Q	M8Outer hexagon rivet nut	10			

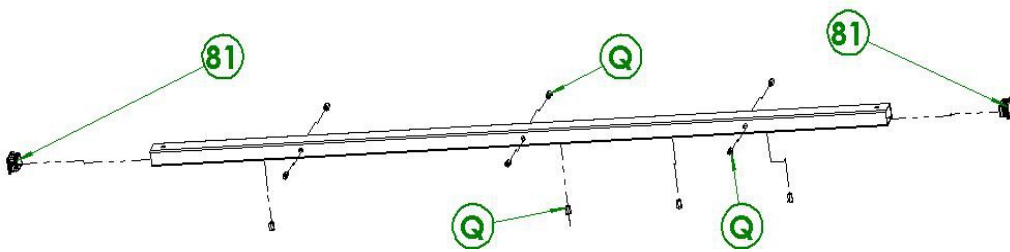



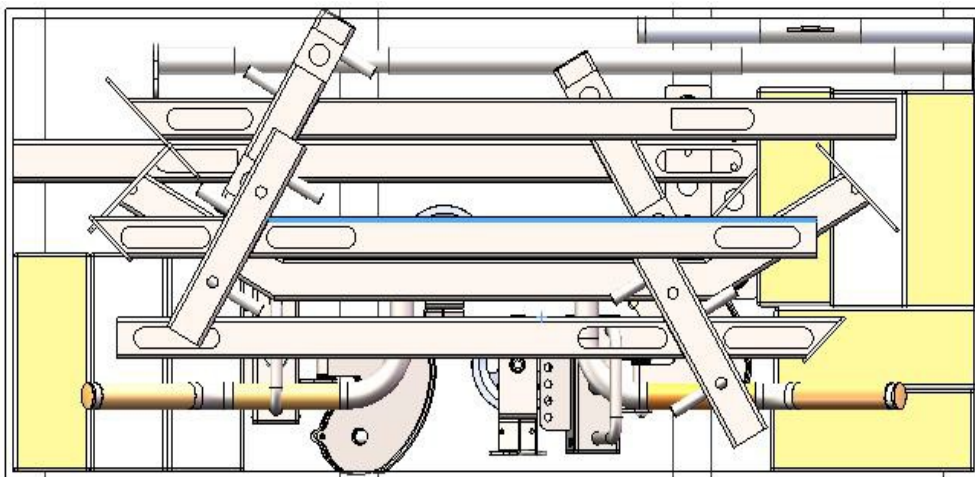
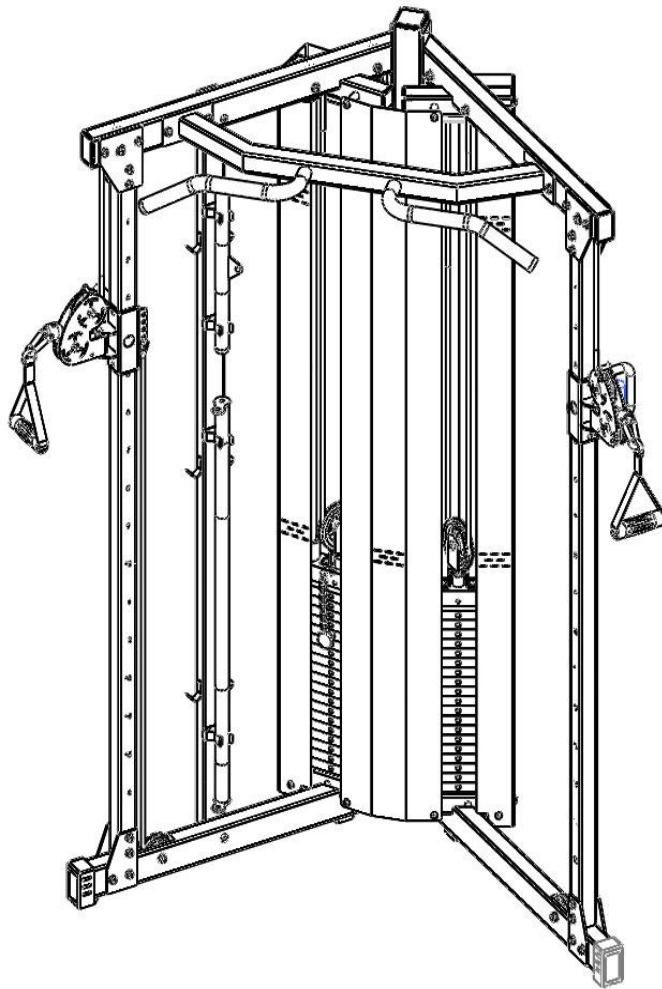







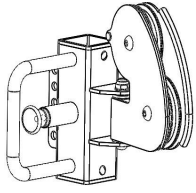
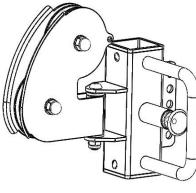

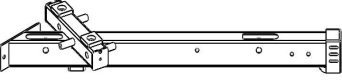
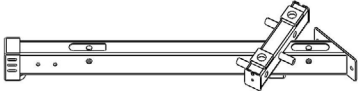
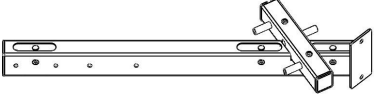
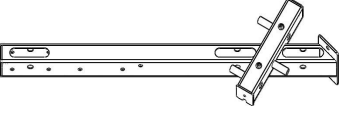
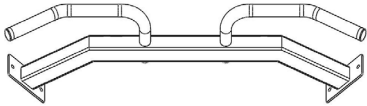
Inner diameter of wooden box: 1250\*550\*320mm

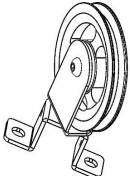

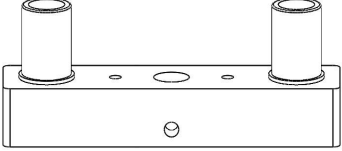

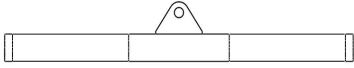
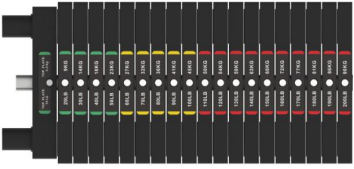

# PACKING LIST

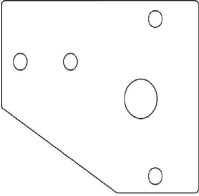
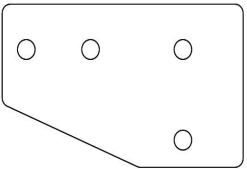
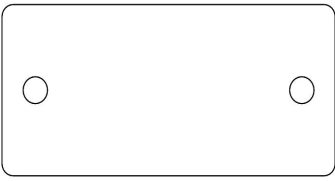

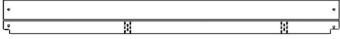
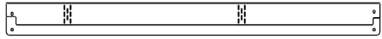
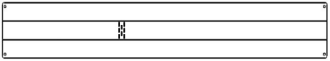
## Packing List-1

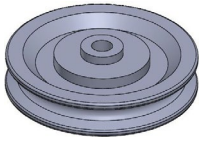
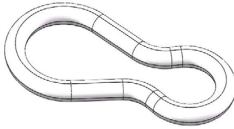
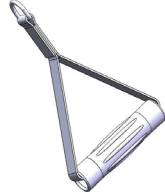
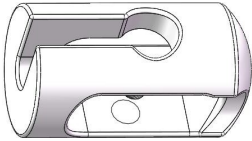
		
NO.1 Functional trainer left pulley*1pc	NO.2 Functional trainer right pulley*1pcs*1pc	NO.3 Rear column welding group*1pc
		
NO.4 Left base welding group*1pc	NO.5 Right base welding group*1pc	NO.6 Right top welding group*1pc
		
NO.7 Left top welding group*1pc	NO.8 Beam as-upper*1pc	NO.9 Storage riser welding group*1pc
		
NO.10 Lifting pulley assembly right*1pc	NO.11 Lifting pulley assembly left*1pc	NO.12 Cast iron counterweight*2pcs
		
NO.13 Push rod welding group*1pc	NO.14 Low tension welding group*1pc	Stack weight stickers*1pc

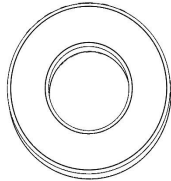
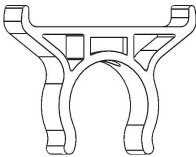
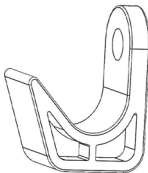
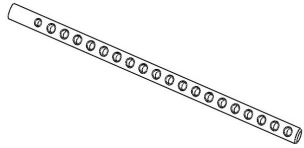
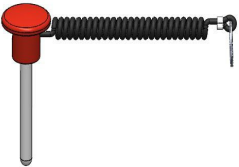
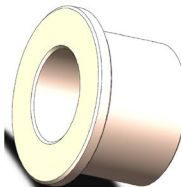
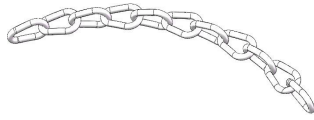
## Packing list-2

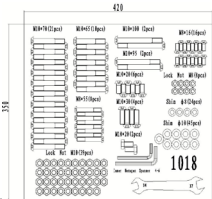
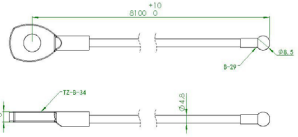
		
No.15 Upper assembly board * 4 pcs	No.16 Lower assembly board * 4 pcs	No.17 Small assembly board * 2 pcs

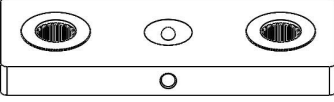
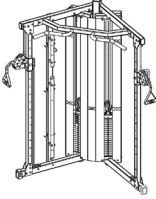
		
No.18 Stainless steel lettering tube*2 pcs	No.19 Side guard left *1 pc	No.20 Side guard plate right*1 pc
		
No.21 Front guard plate *1	No.22 Guide rod $\text{Ø}25*2.0*1818*4$ 件	No.23 Optical axis fixed block * 2 pcs
		
No.24 $\text{Ø}90$ pulley*10 pcs	No.25 Safety hook * 4 pcs	No.26 Low pull handle*2 pcs
		
No.27 Card slot set * 2 pcs	No.28 Rubber cover*2 pcs	No.29 Round shock cushion * 4 pcs
		
No.30 Clip set * 4 pcs	No.31 Plastic hook * 6 pcs	No.61 Center rod 20 holes * 2 pcs
		
No.33 $\text{Ø}10*100$ counterweight bolt*2 pcs	No.34 Pulley limit set * 20 pcs	No.35 Chain 0.35m*2 pcs
		
No.55 Biceps*1 pc	No.56 Blister pack*1 pc	No.57 Wire rope*2 pcs

					
No.58	Weight piece * 38 pcs	No.59	Manual *1	No.60	Foot pocket *1
					
Black warning label*2					

# PACKING STEPS

## Packing steps

Number of steps	project number	name	Quantity	project number	name	Quantity
1	No.58	Counterweight	38	No.11	Hanging pulley combination	1
	No.14	Low-stretch welding group	1	No.12	Weight combination	2
	No.1	Asuka pulley left	1	No.13	Push rod welding group	1
	No.2	Asuka pulley block right	1			
	No.10	Hanging pulley combination	1			

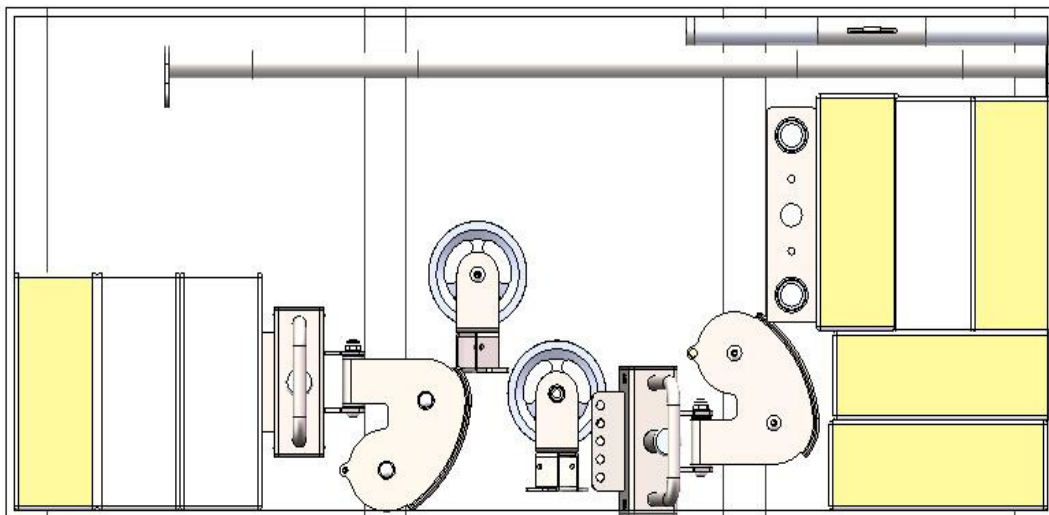
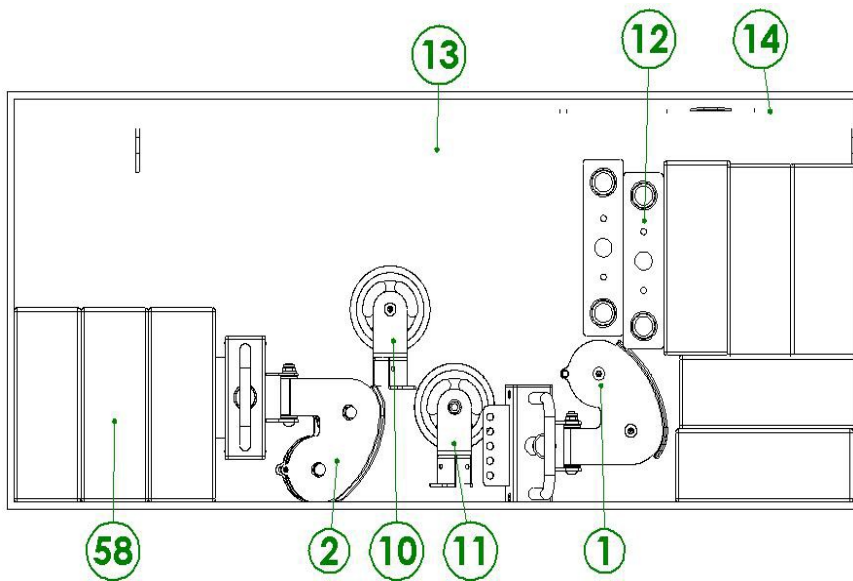

## Packing steps

Number of steps	project number	name	Quantity	project number	name	Quantity
2	No.4	Left base welding group	1			
	No.5	Right base welding group	1			
	No.6	Right top welding group	1			
	No.8	Upper beam assembly	1			

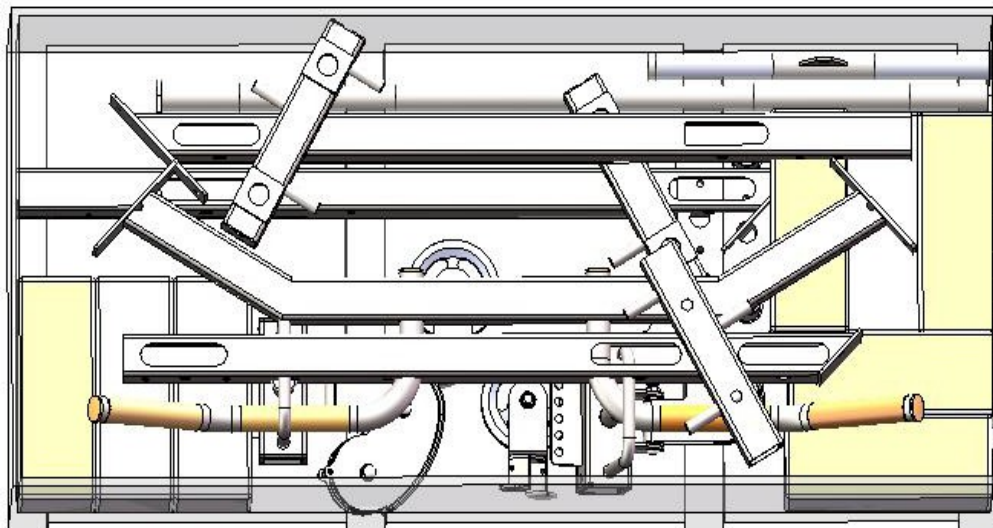
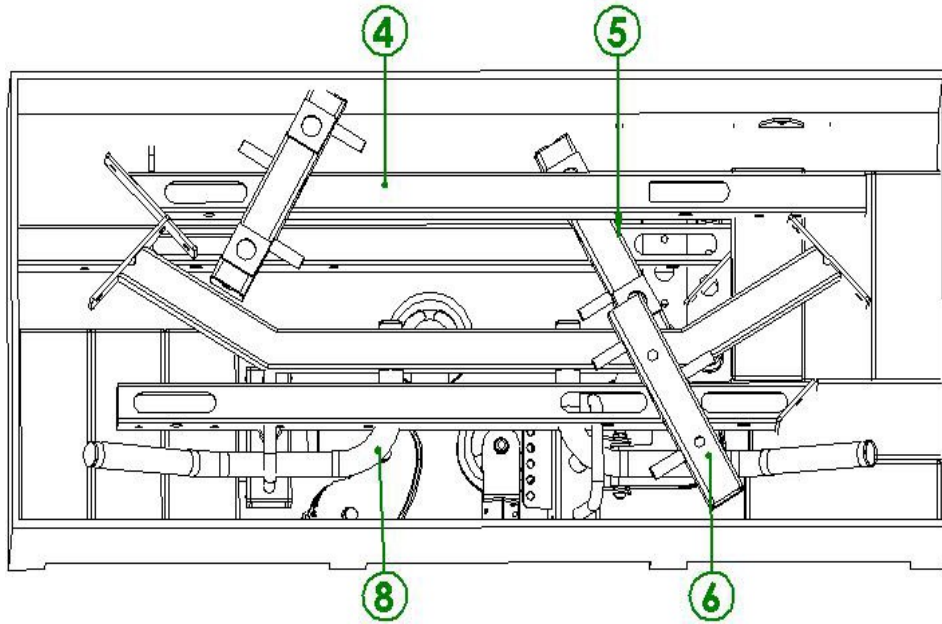

## Packing steps

Number of	project	name	Quantity	project number	name	Quantity
3	No.7	Left top welding group	1			

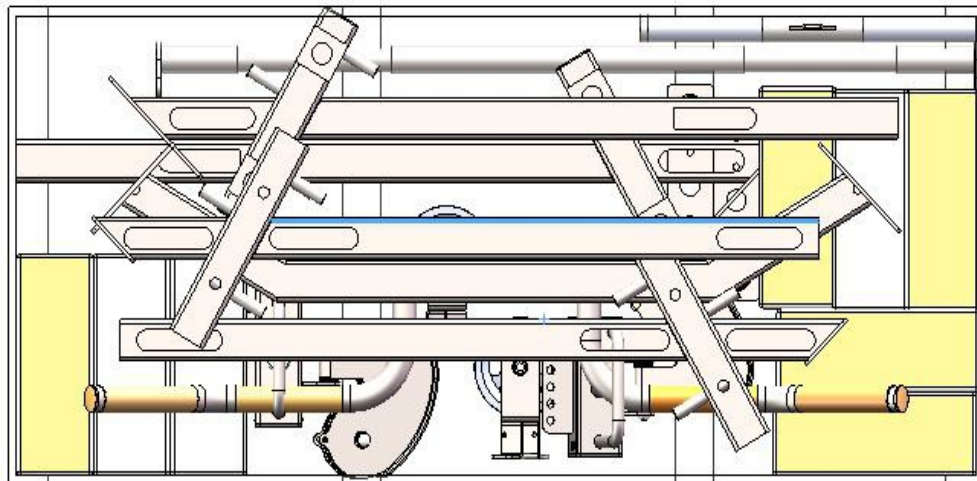
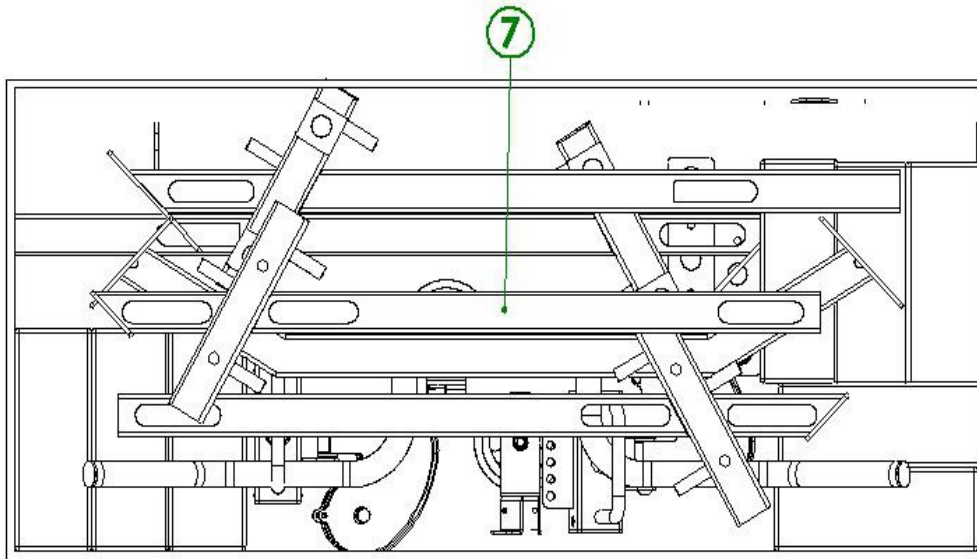

# CARTON PACKING STEPS

## Carton packing steps

Number of steps	project number	name	Quantity	project number	name	Quantity
1	No.19	Side guard right	1	No.20	Side guard right	1
	No.3	Rear column welding group	1			
	No.18	Stainless steel lettering tube	2			
	No.22	Guide rod $\varnothing 25*2.0*1818$	4			

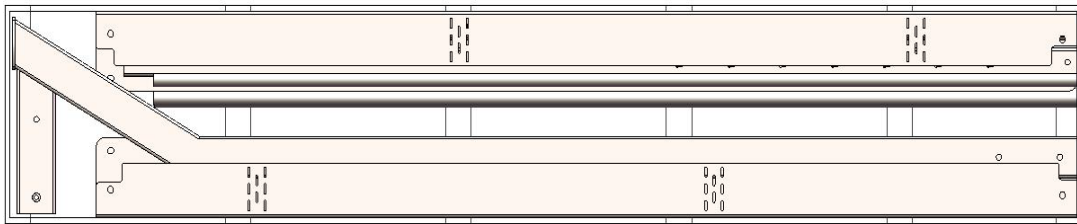
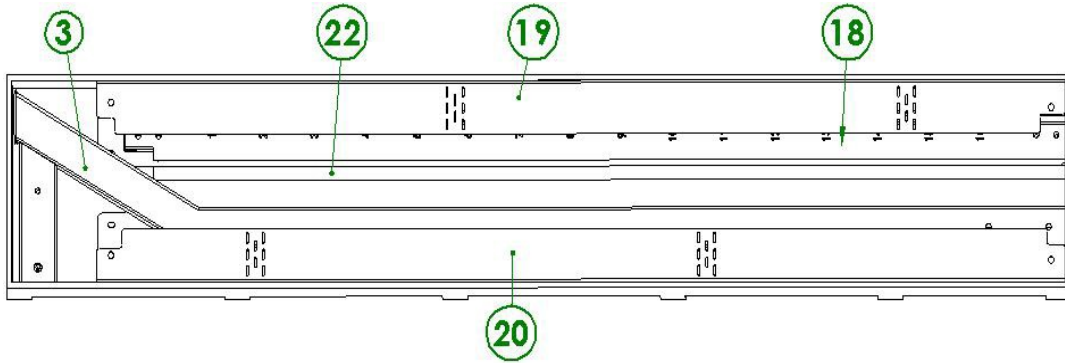

Carton inner diameter size 2100\*370\*160mm



### Carton packing steps

Number of steps	project number	name	Quantity	project number	name	Quantity
2	No.9	Storage riser welding group	1			
	No.21	Front guard	1			

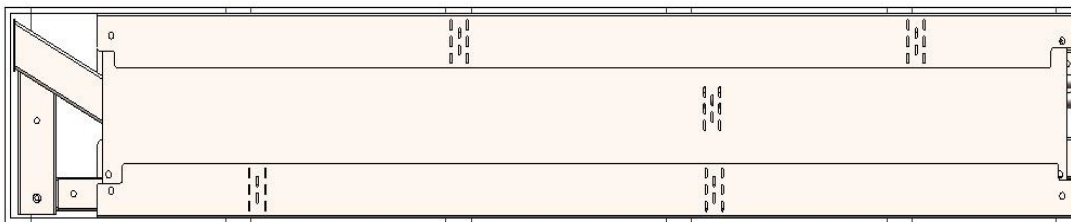
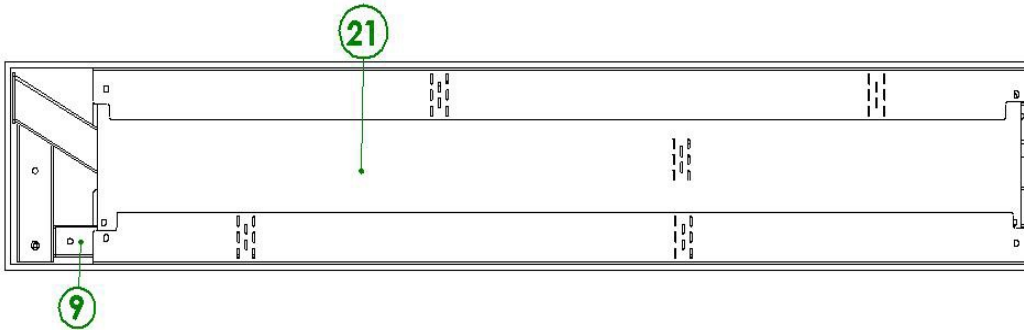

The products in the carton should be packed in bubble bags around

The packing diagram does not include all the accessories. The packing accessories are subject to the packing schedule. The counterweights are packed according to the actual number of pcs. The remaining small accessories that are not marked are separately packed together and placed in the empty gaps of the box to complete all the packing. Box and seal the box.